



SECTION NAME

Date : 04/03/2024
Time : 3 Hours 0 Minutes

2023_Previous Year Paper - 1
Marks : 300

Mathematics

1. The straight lines l_1 and l_2 pass through the origin and trisect the line segment of the line $L : 9x + 5y = 45$ between the axes. If m_1 and m_2 are the slopes of the lines l_1 and l_2 , then the point of intersection of the line $y = (m_1 + m_2)x$ with L lies on

A) $y - 2x = 5$ B) $6x + y = 10$ C) $y - x = 5$ D) $6x - y = 15$

SOL:

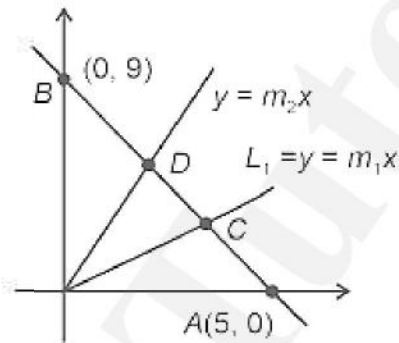

$$L : 9x + 5y = 45$$

$$\Rightarrow \frac{x}{5} + \frac{y}{9} = 1$$

$$\therefore C \equiv \left(\frac{10}{3}, 3 \right)$$

$$\therefore D \equiv \left(\frac{5}{3}, 6 \right)$$

$$\therefore m_1 = \frac{9}{10}, m_2 = \frac{6 \times 3}{5} = \frac{18}{5}$$

$$\therefore y = \left(\frac{9}{10} + \frac{36}{10} \right) x = \frac{9}{2} x \dots\dots\dots(i)$$

So, intersection point with L

Loading [MathJax]/jax/element/mml/optable/BasicLatin.js

$$\frac{y}{9} + \frac{x}{5} = 1 \Rightarrow y = \frac{9}{5}x - \frac{9}{5}$$

∴ Option (3) is correct.

2. If the ratio of the fifth term from the beginning to the fifth term from the end in the expansion of

$\left(\sqrt[4]{2} + \frac{1}{\sqrt[4]{3}}\right)^n$ is $\sqrt{6}:1$, then the third term from the beginning is:

A) $30\sqrt{2}$ B) $30\sqrt{3}$ C) $60\sqrt{2}$ D) $60\sqrt{3}$

SOL:

Given expansion $\left(\sqrt[4]{2} + \frac{1}{\sqrt[4]{3}}\right)^n$

(5th term from beginning)

$$T_5 = {}^nC_4 \left(\sqrt[4]{2}\right)^{n-4} \cdot \left(\frac{1}{\sqrt[4]{3}}\right)^4$$

(5th term from end)

$$T'_5 = {}^nC_4 \left(\frac{1}{\sqrt[4]{3}}\right)^{n-4} \left(\sqrt[4]{2}\right)^4$$

$$\text{Now, } \frac{T_5}{T'_5} = \frac{\sqrt{6}}{1} \Rightarrow 2^{\frac{n-4}{4}} \cdot 3^{-\frac{n-4}{4}} = \sqrt{6}$$

$$\therefore (\sqrt{6})^{\frac{n-4}{2}} = (\sqrt{6})$$

$$\therefore n = 10$$

$$\therefore T_3 = {}^{10}C_2 \left(\sqrt[4]{2}\right)^8 \left(\frac{1}{\sqrt[4]{3}}\right)^2 = \frac{45 \times 4}{\sqrt{3}}$$

$$= 60\sqrt{3}$$

3. The mean and variance of a set of 15 numbers are 12 and 14 respectively. The mean and variance of another set of 15 numbers are 14 and σ^2 respectively. If the variance of all the 30 numbers in the two sets is 15, then σ is equal to

Loading [MathJax]/jax/element/mml/optable/BasicLatin.js

A) 10 B) 11 C) 9 D) 12

SOL: $\sum x_i = 15 \times 12$ and $\frac{\sum x_i^2}{15} - 12^2 = 14$

And $\sum y_i = 15 \times 14$ and $\frac{\sum y_i^2}{15} - 14^2 = \sigma^2$

Now, $13 = \frac{(14+144) \times 15 + (\sigma^2 + 196) \times 15}{30} - 13^2$

$\therefore \sigma^2 = 10$

4. A pair of dice is thrown 5 times. For each throw, a total of 5 is considered a success. If the probability of at least 4 successes is $\frac{k}{3^{11}}$, then k is equal to

A) 82 B) 75 C) 164 D) 123

SOL: P(success) = $\frac{4}{36} = \frac{1}{9}$

P(failure) = $\frac{8}{9}$

\therefore Required probability = ${}^5C_4 \left(\frac{1}{9}\right)^4 \frac{8}{9} + {}^5C_5 \left(\frac{1}{9}\right)^5$

= $5 \cdot \frac{8}{9^5} + \frac{1}{9^5} = \frac{41}{9^5}$

$\frac{41}{3^{11}}$

$\therefore k = 123$

5. Let the position vectors of the points A, B, C and D be $5\hat{i} + 5\hat{j} + 2\lambda\hat{k}$, $\hat{i} + 2\hat{j} + 3\hat{k}$, $-2\hat{i} + \lambda\hat{j} + 4\hat{k}$ and $-\hat{i} + 5\hat{j} + 6\hat{k}$. Let the set $S = \{\lambda \in \mathbb{R} : \text{the points A, B, C and D are coplanar. The } \sum \lambda \in S (\lambda + 2)^2 \text{ is equal to}$

A) 25 B) $\frac{37}{2}$ C) 13 D) 41

SOL: A(5, 5, 2λ)

B(1, 2, 3)

C(-2, λ, 4)

D(-1, 5, 6)

→

Loading [MathJax]/jax/element/mml/optable/BasicLatin.js

$$\rightarrow AC(-7, \lambda - 5, 4 - 2\lambda)$$

$$\rightarrow AD(-6, 0, 6 - 2\lambda)$$

$$\therefore [AB \ AC \ AD] = 0$$

$$\begin{vmatrix} -4 & -3 & 3 - 2\lambda \\ -7 & \lambda - 5 & 4 - 2\lambda \\ -6 & 0 & 6 - 2\lambda \end{vmatrix} = 0$$

$$-4(\lambda - 3)(\lambda - 2) = 0$$

$$\therefore \lambda = 3, \lambda = 2$$

$$\sum_{\lambda \in S} (\lambda + 2)^2 = 5^2 + 4^2 = 41$$

6.

Let $I(x) = \int \frac{x^2(x \sec^2 x + \tan x)}{(x \tan x + 1)^2} dx$. If $I(0) = 0$, then $I\left(\frac{\pi}{4}\right)$ is equal to

A) $\log_e \frac{(\pi+4)^2}{16} + \frac{\pi^2}{4(\pi+4)}$ **B)** $\log_e \frac{(\pi+4)^2}{16} - \frac{\pi^2}{4(\pi+4)}$ **C)** $\log_e \frac{(\pi+4)^2}{32} - \frac{\pi^2}{4(\pi+4)}$

D) $\log_e \frac{(\pi+4)^2}{32} + \frac{\pi^2}{4(\pi+4)}$

SOL:

$$\int x^2 \left(\frac{x \sec^2 x + \tan x}{(x \tan x + 1)^2} \right) dx$$

$$= \frac{x^2}{(x \tan x + 1)} + \int \frac{2x}{x \tan x + 1} dx$$

$$I = 2 \int \frac{x}{x \tan x + 1} dx$$

$$= 2 \int \frac{x \cos x}{x \sin x + \cos x} dx$$

$$\text{Let } x \sin x + \cos x = t$$

$$(x \cos x + \sin x - \sin x) dx = dt$$

$$= 2 \int \frac{dt}{t} = 2 \log t + c$$

$$= 2 \log |x \sin x + \cos x| + c$$

$$\begin{aligned} \therefore \int \frac{x^2(x \sec^2 x + \tan x)}{(x \tan x + 1)^2} dx \\ = \frac{-x^2}{x \tan x + 1} + 2 \log |x \sin x + \cos x| + c \end{aligned}$$

$$I(0) = 0$$

$$\Rightarrow c = 0$$

$$\begin{aligned} I\left(\frac{\pi}{4}\right) &= -\frac{\left(\frac{\pi}{4}\right)^2}{\frac{\pi}{4} \times 1 + 1} + 2 \log \left| \frac{1}{\sqrt{2}} \left(\frac{\pi}{4}\right) + 1 \right| \\ &= \log_e \frac{(\pi+4)^2}{32} - \frac{\pi^2}{4(\pi+4)} \end{aligned}$$

7. Let $\vec{a} = 2\hat{i} + 3\hat{j} + 4\hat{k}$, $\vec{b} = \hat{i} - 2\hat{j} - 2\hat{k}$ and $\vec{c} = -\hat{i} + 4\hat{j} + 3\hat{k}$. If \vec{d} is a vector perpendicular to both \vec{b} and \vec{c} , and $\vec{a} \cdot \vec{d} = 18$, then $|\vec{a} \times \vec{d}|^2$ is equal to

A) 640 B) 680 C) 720 D) 760

SOL: $\vec{b} \times \vec{c} = 2\hat{i} - \hat{j} + 2\hat{k}$

$$\therefore \vec{d} = \lambda(2\hat{i} - \hat{j} + 2\hat{k})$$

$$\vec{a} \cdot \vec{d} = 18$$

$$\Rightarrow \lambda = 2$$

$$\therefore |\vec{a} \times \vec{d}|^2 = |\vec{a}|^2 \cdot |\vec{d}|^2 - (\vec{a} \cdot \vec{d})^2$$

$$= 720$$

8.

Let $5f(x) + 4f\left(\frac{1}{x}\right) = \frac{1}{x} + 3, x > 0$. Then $18 \int_1^2 f(x) dx$ is equal to

A) $5 \log_e 2 + 3$ B) $10 \log_e 2 + 6$ C) $10 \log_e 2 - 6$ D) $5 \log_e 2 - 3$

SOL:

$$5f(x) + 4f\left(\frac{1}{x}\right) = \frac{1}{x} + 3 \dots\dots(i)$$

Replace $x \rightarrow \frac{1}{x}$

$$5f\left(\frac{1}{x}\right) + 4f(x) = x + 3 \dots\dots(ii)$$

Solving (i) and (ii) we get

$$9f(x) = \frac{5}{x} - 4x + 3$$

$$\int_1^2 f(x) dx = \frac{1}{9} \int_1^2 \left(\frac{5}{x} - 4x + 3 \right) dx$$

$$= \frac{1}{9} \left[5 \log x - 2x^2 + 3x \right]_1^2$$

$$= \frac{1}{9} [5 \log 2 - 3]$$

$$\therefore 18 \int_1^2 f(x) dx = 10 \log_e 2 - 6$$

9. Statement $(P \Rightarrow Q) \wedge (R \Rightarrow Q)$ is logically equivalent to

A) $(P \Rightarrow R) \vee (Q \Rightarrow R)$ **B)** $(P \vee R) \Rightarrow Q$ **C)** $(P \Rightarrow R) \wedge (Q \Rightarrow R)$ **D)** $(P \wedge R) \Rightarrow Q$

SOL: $(P \rightarrow Q) \wedge (R \rightarrow Q)$

$$\Rightarrow (P' \vee Q) \wedge (R' \vee Q)$$

$$\Rightarrow Q \vee (P' \wedge R')$$

$$\Rightarrow Q \vee (P \wedge R)'$$

$$\Rightarrow (P \wedge R)' \vee Q$$

$$\Rightarrow (P \wedge R) \rightarrow Q$$

10. If the system of equations

$$x + y + az = b$$

$$2x + 5y + 2z = 6$$

$$x + 2y + 3z = 3$$

has infinitely many solutions, then $2a + 3b$ is equal to

A) 25 **B)** 20 **C)** 23 **D)** 28

SOL: $x + y + az = b \dots(i)$

$$2x + 5y + 2z = 6 \dots(ii)$$

$$x + 2y + 3z = 3 \dots(iii)$$

Loading [MathJax]/jax/element/mml/optable/BasicLatin.js

3 (iii) – (ii)

$$x + y + 7z = 3$$

$$x + y + az = b$$

$\therefore a = 7, b = 3$ (\because solutions are infinite)

$$\therefore 2a + 3b$$

$$= 14 + 9 = 23$$

11. From the top A of a vertical wall AB of height 30 m, the angles of depression of the top P and bottom Q of a vertical tower PQ are 15° and 60° respectively, B and Q are on the same horizontal level. If C is a point on AB such that $CB = PQ$, then the area (in m^2) of the quadrilateral BCPQ is equal to

A) $300(\sqrt{3} - 1)$ B) $300(\sqrt{3} + 1)$ C) $600(\sqrt{3} - 1)$ D) $200(\sqrt{3} - 1)$

SOL:

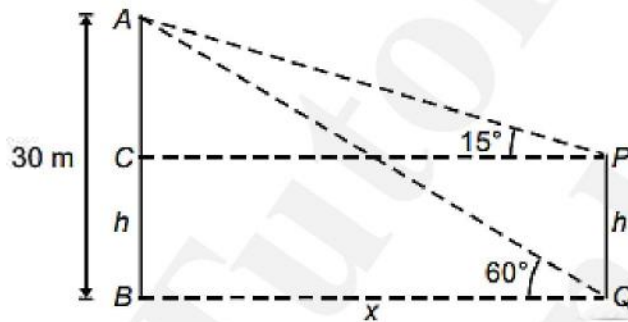

$$\frac{30}{x} = \sqrt{3};$$

$$\frac{30-h}{x} = 2 - \sqrt{3}$$

$$\Rightarrow 30 - h = 20\sqrt{3} - 30$$

$$\Rightarrow x = 10\sqrt{3}$$

$$\Rightarrow h = 60 - 20\sqrt{3}$$

\therefore area = hx

$$= (60 - 20\sqrt{3})10\sqrt{3}$$

$$= 200\sqrt{3}(3 - \sqrt{3})$$

$$= 600(\sqrt{3} - 1)$$

\therefore (2) is correct

12. One vertex of a rectangular parallelepiped is at the origin O and the lengths of its edges along x , y and z axes are 3, 4 and 5 units respectively. Let P be the vertex $(3, 4, 5)$. Then the shortest distance between the diagonal OP and an edge parallel to z axis, not passing through O or P is
- A) $\frac{12}{\sqrt{5}}$ B) $12\sqrt{5}$ C) $\frac{12}{5\sqrt{5}}$ D) $\frac{12}{5}$

SOL:

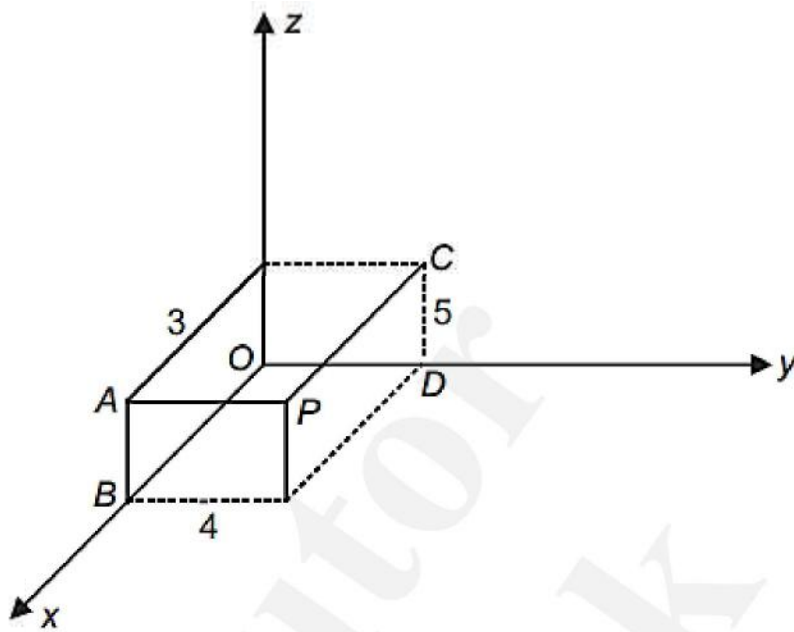

$$\text{Line } OP: \frac{x}{3} = \frac{y}{4} = \frac{z}{5}$$

$$\text{Line } AB: \frac{x-3}{0} = \frac{y}{0} = \frac{z}{1}$$

$$\vec{n}_1 \times \vec{n}_2 = \begin{vmatrix} \hat{i} & \hat{j} & \hat{k} \\ 3 & 4 & 5 \\ 0 & 0 & 1 \end{vmatrix}$$

$$= \hat{i}(4) - \hat{j}(3) + \hat{k}(0)$$

$$= 4\hat{i} - 3\hat{j}$$

$$\text{Distance} = \frac{\left(\begin{matrix} \vec{r}_2 - \vec{r}_1 \\ a_2 - a_1 \end{matrix} \right) \cdot \left(\begin{matrix} \vec{n}_1 \times \vec{n}_2 \end{matrix} \right)}{\left| \begin{matrix} \vec{n}_1 \times \vec{n}_2 \end{matrix} \right|}$$

$$= \frac{(3\hat{i}) \cdot (4\hat{i} - 3\hat{j})}{5}$$

Option (4) is correct.

13. If ${}^{2n}C_3 : {}^nC_3 = 10 : 1$, then the ratio $(n^2 + 3n) : (n^2 - 3n + 4)$ is

A) 35 : 16 **B)** 27 : 11 **C)** 65 : 37 **D)** 2 : 1

SOL: ${}^{2n}C_3 : {}^nC_3 = 10 : 1$

$$\frac{(2n)!}{3!(2n-3)!} \times \frac{3!(n-3)!}{n!} = 10$$

$$\Rightarrow 4(2n-1) = 10n-20$$

$$\Rightarrow n = 8$$

$$\text{Now } \frac{(n^2+3n)}{(n^2-3n+4)} = \frac{64+24}{64-24+4} = \frac{88}{44} = 2$$

14. If the equation of the plane passing through the line of intersection of the planes $2x - y + z = 3$, $4x - 3y + 5z + 9 = 0$ and parallel to the line $\frac{x+1}{-2} = \frac{y+3}{4} = \frac{z-2}{5}$ is $ax + by + cz + 6 = 0$, then $a + b + c$ is equal to

A) 12 **B)** 14 **C)** 15 **D)** 13

SOL: $P_1 = 2x - y + z = 3$

$$P_2 = 4x - 3y + 5z + 9 = 0$$

$$P_1 = \lambda P_2 = 0$$

$$(2x - y + z - 3) + \lambda(4x - 3y + 5z + 9) = 0$$

$$P_3 = (2 + 4\lambda)x - (1 + 3\lambda)y + (1 + 5\lambda)z - (3 - 9\lambda) = 0$$

$$P_3 \text{ is parallel to } \frac{x+1}{-2} = \frac{y+3}{4} = \frac{z-2}{5}$$

$$-2(2 + 4\lambda) - 4(1 + 3\lambda) + 5(1 + 5\lambda) = 0$$

$$-3 + 5\lambda = 0$$

$$\Rightarrow \lambda = \frac{3}{5}$$

$$P_3 : \frac{22x}{5} - \frac{14y}{5} + \frac{20z}{5} + \frac{12}{5} = 0$$

$$P_3 = 11x - 7y + 10z + 6 = 0$$

$$b = -7$$

$$c = 10$$

$$\therefore a + b + c = 11 - 7 + 10 = 14$$

15. The sum of the first 20 terms of the series $5 + 11 + 19 + 29 + 41 + \dots$ is

- A) 3520 B) 3450 C) 3250 D) 3420

$$\text{SOL: } S = 5 + 11 + 19 + 29 + 41 + \dots + T_n$$

$$S = 5 + 11 + 19 + 29 + \dots + T_{n-1} + T_n$$

$$\overline{T_n = 5 + 6 + 8 + \dots + (T_n - T_{n-1})}$$

$$T_n = n^2 + 3n + 1$$

$$S_n = \sum T_n = \sum n^2 + 3 \sum n + \sum 1$$

$$= \frac{n(n+1)(2n+1)}{6} + \frac{3n(n+1)}{2} + n$$

$$n = 20$$

$$S_{20} = \frac{20 \times 21 \times 41}{6} + \frac{3 \times 20 \times 21}{2} + 20$$

$$= 3520$$

16. Let $a_1, a_2, a_3, \dots, a_n$ be n positive consecutive terms of an arithmetic progression. If $d > 0$ is its common difference, then

lim is

- A) B) C) 1 D) 0

SOL:

17. Let $A = (a_{ij})$, where $a_{ij} \neq 0$ for all i, j and $A^2 = I$. Let a be the sum of all diagonal elements of A and $b = |A|$.

Then $3a^2 + 4b^2$ is equal to

- A) 4 B) 14 C) 7 D) 3

SOL: Let

18. The sum of all the roots of the equation is:

- A) B) C) D)

SOL: **Case: I**

(rejected)

Case: II

Loading [MathJax]/jax/element/mml/optable/BasicLatin.js

(rejected)

19. If, then at (2, 2) is equal to:

- A) B) C) D)

SOL: Differentiating both sides w. r. t. x,

Putting $x = 2 = y$,

20. Let ,

, where $[t]$ denotes greatest integer function. Then,

- A) B) C) D)

SOL:

21. The coefficient of x^{18} in the expansion of is

SOL: General term

For coefficient of x^{18} , put $60 - 7r = 18$

$\Rightarrow r = 6$

Coefficient of

22. Let and $[t]$ be the greatest integer $\leq t$. Then the number of points, where the function $f(x)=[a + 13 \sin x]$, $x \in (0, \pi)$ is not differentiable, is

SOL: $f(x) = [a + 13 \sin x]$, $x \in (0, \pi)$, $a \in Z$

$= f(x) = [13 \sin x]$

Let $g(x) = 13 \sin x$

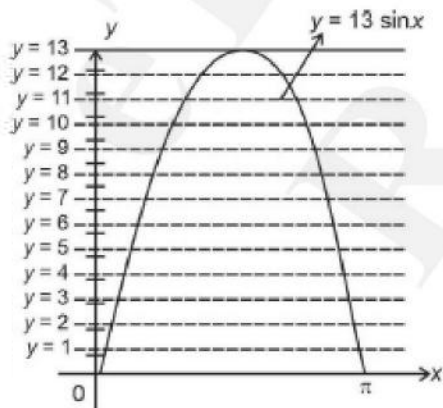

$f(x)=[13 \sin x]$ is not differentiable at intersection points of $y =K$, $K \in [1,13]$, $K \in Z$

\Rightarrow Points of non-differentiability = 25

23. The number of ways of giving 20 distinct oranges to 3 children such that each child gets at least one orange is

SOL: Number of ways

coefficient of x^{20} in $(x + x^2 + \dots + x^{18})^3$

Note: Here 3 children are considered identical but children showed be considered distinct and number of ways should be number of ways

24. If the area of the region is equal to , then the natural number n is equal to

SOL:

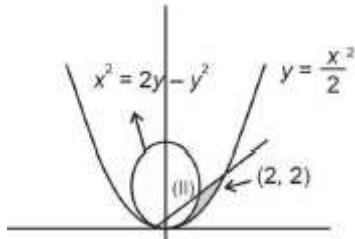

$n = 5$

25. A circle passing through the point $P(\alpha, \beta)$ in the first quadrant touches the two coordinate axes at the points A and B. The point P is above the line AB. The point Q on the line segment AB is the foot of perpendicular from P on AB. If PQ is equal to 11 units, then the value of $\alpha\beta$ is

SOL: $(x - r)^2 + (y - r)^2 = r^2$ passes through (α, β)

AB : $x + y = r$

Q(h, k)

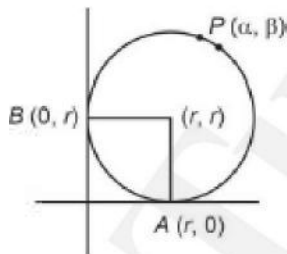

$(h, k) =$

or

or

or $2\alpha\beta = 242$

$\Rightarrow \alpha\beta = 121$

26. Let the image of the point $P(1, 2, 3)$ in the plane $2x - y + z = 9$ be Q. If the coordinates of the point R are $(6, 10, 7)$, then the square of the area of the triangle PQR is

SOL:

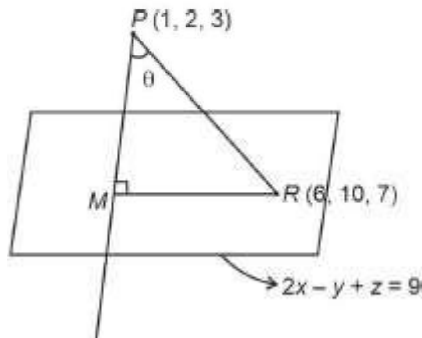

R lies on plane

Area

27. Let $y=y(x)$ be a solution of the differential equation $(x \cos x) dy + (xy \sin x + y \cos x - 1) dx = 0$, . If, then is equal to

SOL: \therefore Integrating factor =

Thus

Hence

28. Let $A = \{1, 2, 3, 4, \dots, 10\}$ and $B = \{0, 1, 2, 3, 4\}$. The number of elements in the relation is

SOL: $A = \{1, 2, 3, \dots, 10\}$ $B = \{0, 1, 2, 4\}$

$(a, b) \in A \times A$ such that

$$2(a - b)^2 + 3(a - b) - k = 0$$

where $k \in \{0, 1, 2, 3, 4\}$

We should have

$9 - 4 \times 2(-k)$ a perfect square for any possible (a, b) i.e, $9 + 8k$ is perfect square

$$\Rightarrow k = 0 \text{ or } k = 2$$

for $k = 0$, $2(a - b)^2 + 3(a - b) = 0$

$$\Rightarrow a - b = 0 \Rightarrow (a, b) \in \{(1, 1), (2, 2), \dots, (10, 10)\}.$$

\Rightarrow Total 10 elements belonging to R.

is not possible

$$\text{or } k = 0 \quad 2(a - b) + 3(a - b) - 2 = 0$$

(not possible)

$$\Rightarrow (a, b) \in \{(1, 3), (2, 4), \dots, (8, 10)\}$$

\Rightarrow 8 element belonging to R

Total = 18

29. Let the tangent to the curve at the point $P(1, 3)$ on it meet the y-axis at A. Let the line passing through P and parallel to the line $x - 3y = 6$ meet the parabola at B. If B lies on the line $2x - 3y = 8$, then is equal to

SOL:

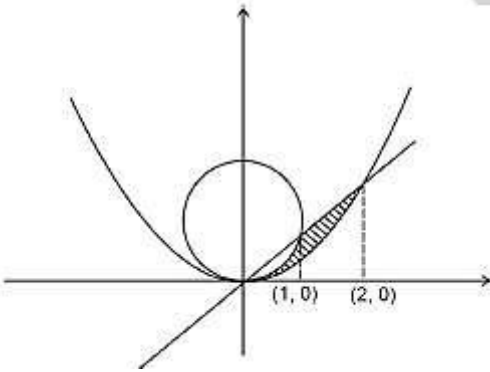

Given region are :

The required area is as shown

Required area

$$n=5$$

30. Let the point $(p, p + 1)$ lie inside the region . If the set of all values of p is the interval (a, b) , then $b^2 + b - a^2$ is equal to

SOL:

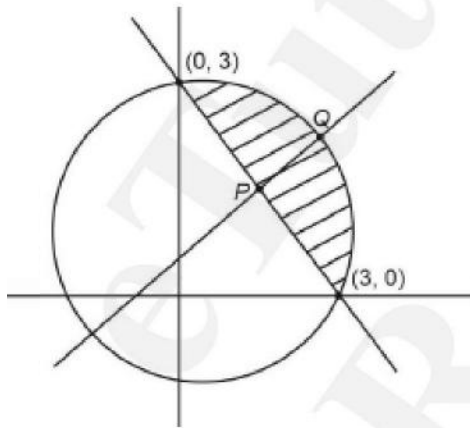
 $(p, p + 1)$ lies on $y - x = 1$
 \therefore Solving $y - x = 1$ and $x + y = 3$

$$P(1, 2)$$

 solving $y - x = 1$ and $x^2 + y^2 = 9$

$$x^2 + (1 + x)^2 = 9 \Rightarrow 2x^2 + 2x - 8 = 0$$

$$\Rightarrow x^2 + x - 4 = 0$$

 $\therefore a = 1, b^2 + b = 4$ [using (i)]

Physics

31. A particle is moving with constant speed in a circular path. When the particle turns by an angle 90° , the ratio of instantaneous velocity to its average velocity is x . The value of x will be

A) 2 B) 5 C) 1 D) 7

SOL: Instantaneous velocity = ωR

Time taken

Displacement

Average velocity

$$\Rightarrow x = 2$$

32. A source supplies heat to a system at the rate of 1000 W. If the system performs work at a rate of 200 W. The rate at which internal energy of the system increases is

A) 600 W B) 800 W C) 500 W D) 1200 W

SOL:

33. The number of air molecules per cm^3 increased from 3×10^{19} to 12×10^{19} . The ratio of collision frequency of air molecules before and after the increase in number respectively is:

A) 0.75 B) 1.25 C) 0.50 D) 0.25

SOL: $\Rightarrow f \propto n$

34. The energy levels of an hydrogen atom are shown below. The transition corresponding to emission of shortest wavelength is

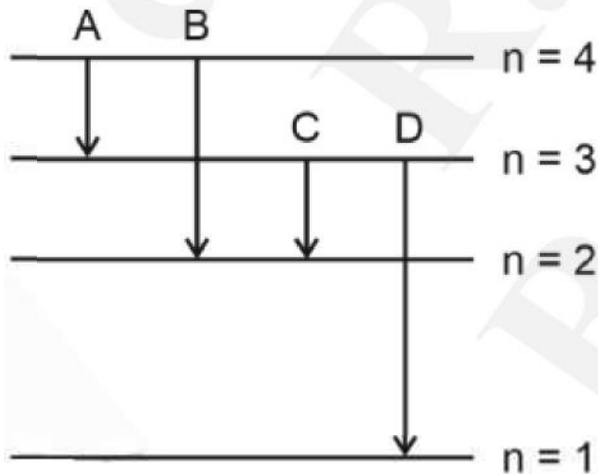

A) D B) A C) B D) C

SOL: Shortest wavelength will correspond to highest energy difference de-excitation, which in the given figure will correspond to transition from $n = 3$ to $n = 1$.

Loading [MathJax]/jax/element/mml/optable/BasicLatin.js a coil by

- A. moving the coil with uniform speed inside uniform magnetic field
- B. moving the coil with non uniform speed inside uniform magnetic field
- C. rotating the coil inside the uniform magnetic field
- D. changing the area of the coil inside the uniform magnetic field

Choose the correct answer from the options given below:

- A)** B and C only **B)** A and C only **C)** C and D only **D)** B and D only

SOL: If flux can change with respect to time then emf can be produced in the coil.

36. A mass m is attached to two strings as shown in figure. The spring constants of two springs are K_1 and K_2 . For the frictionless surface, the time period of oscillation of mass m is

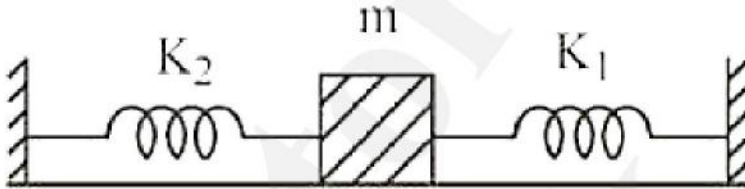

- A)** **B)** **C)** **D)**

SOL: Two springs are effectively in parallel

$$\Rightarrow K = K_1 + K_2$$

37. Given below are two statements: one is labelled as **Assertion A** and the other is labelled as **Reason R**.

Assertion A: When a body is projected at an angle 45° , its range is maximum.

Reason R: For maximum range, the value of $\sin 2\theta$ should be equal to one.

In the light of the above statements, choose the **correct** answer from the options given below:

- A)** A is false but R is true **B)** A is true but R is false
- C)** Both A and R are correct and R is the correct explanation of A
- D)** Both A and R are correct but R is NOT the correct explanation of A

SOL: On a horizontal ground projectile for $R_{\max} \sin(2\theta) = 1 \Rightarrow \theta = 45^\circ$

38. A small block of mass 100 g is tied to a spring of spring constant 7.5 N/m and length 20 cm . The other end of spring is fixed at a particular point A. If the block moves in a circular path on a smooth horizontal surface with constant angular velocity 5 rad/s about point A, then tension in the spring is

- A)** 0.75 N **B)** 0.25 N **C)** 0.50 N **D)** 1.5 N

SOL: $kx = T = m\omega^2(r + x)$

$$7.5x = 2.5(0.2 + x)$$

$$\Rightarrow kx = 0.75 \text{ N}$$

39. For a uniformly charged thin spherical shell, the electric potential (V) radially away from the centre (O) of shell can be graphically represented as

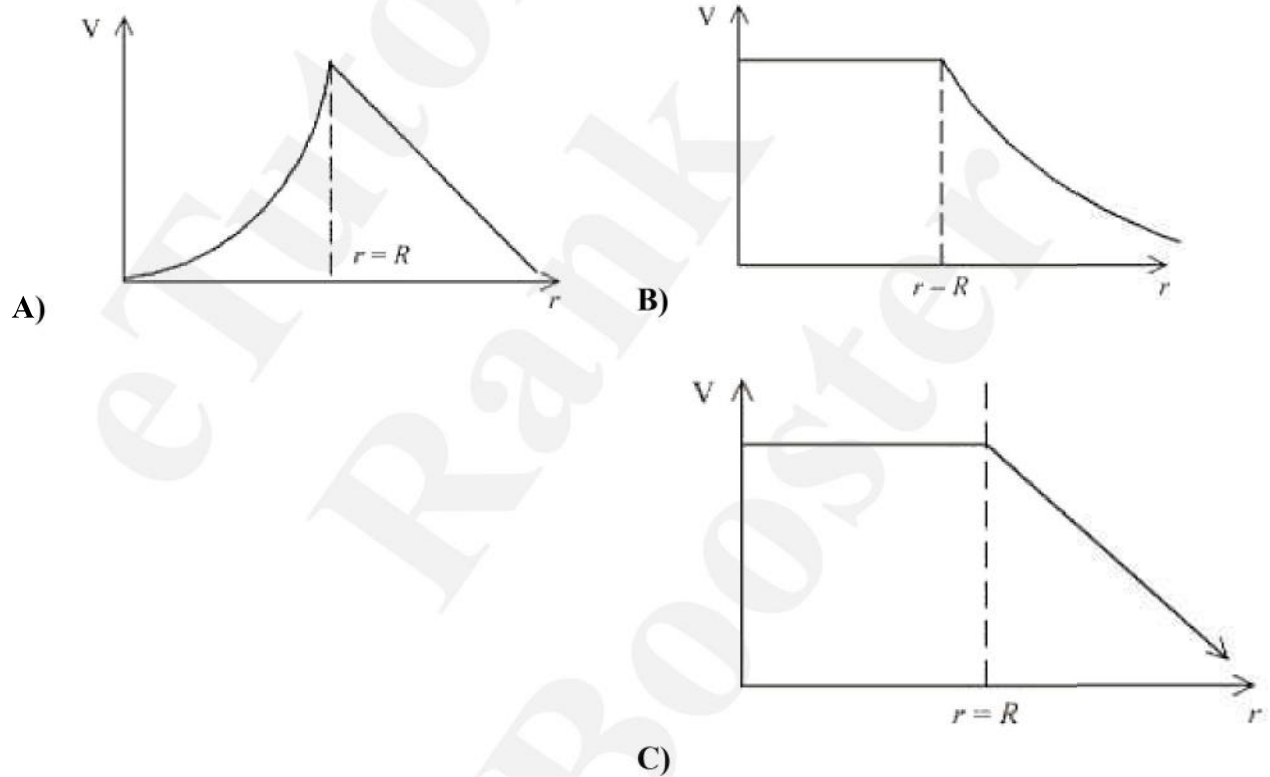
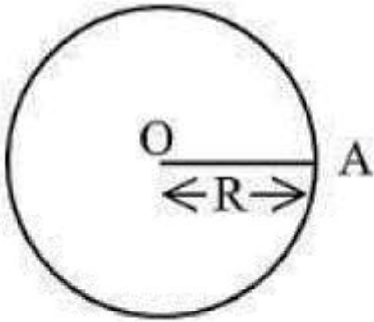

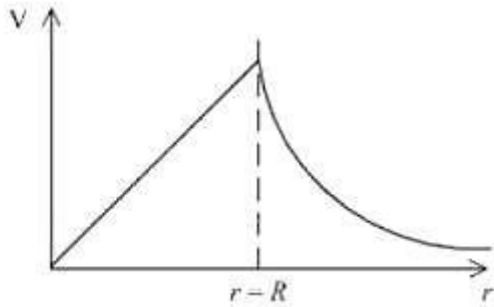

D)

SOL: Electric potential inside shell will remain constant.

Outside the shell



⇒

40. Two resistance are given as $R_1 = (10 \pm 0.5) \Omega$ and $R_2 = (15 \pm 0.5) \Omega$. The percentage error in the measurement of equivalent resistance when they are connected in parallel is

A) 6.33 B) 2.33 C) 5.33 D) 4.33

SOL: in percentage = 4.33%

41. A planet has double the mass of the earth. Its average density is equal to that of the earth. An object weighing W on earth will weigh on that planet:

A) W B) $2^{1/3} W$ C) $2W$ D) $2^{2/3} W$

SOL:

42. A monochromatic light wave with wavelength and frequency in air enters another medium. If the angle of incidence and angle of refraction at the interface are 45° and 30° respectively, then the wavelength and frequency of the refracted wave are:

A) B) C) D)

SOL:

43. A small ball of mass M and density is dropped in a viscous liquid of density . After some time, the ball falls with a constant velocity. What is the viscous force on the ball?

A) B) C) D)

SOL: At terminal velocity

44. By what percentage will the transmission range of a TV tower be affected when the height of the tower is increased by 210/9

- A) 15% B) 12% C) 10% D) 14%

SOL: Now $h' = 1.21h$

$$\Rightarrow R' = 1.1R$$

\Rightarrow Range increases by 10%

45. Name the logic gate equivalent to the diagram attached

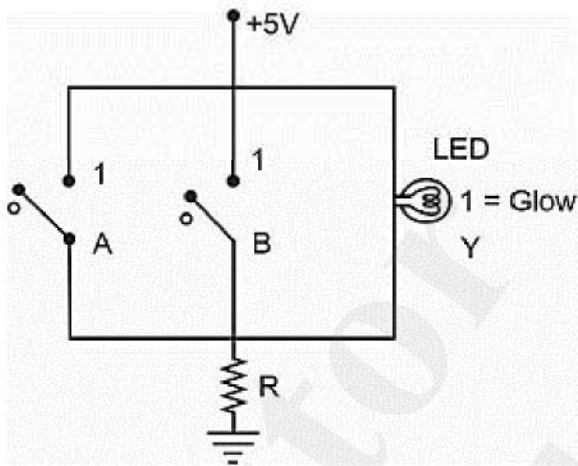

- A) NAND B) AND C) NOR D) OR

SOL: Truth table corresponding to given situation

A	B	Out
1	1	0
1	0	0
0	1	0
0	0	1

\Rightarrow The truth table corresponds to NOR gate.

46. For the plane electromagnetic wave given by $E = E_0 \sin(\omega t - kx)$ and $B = B_0 \sin(\omega t - kx)$, the ratio of average electric energy density to average magnetic energy density is
- A) $1/2$ B) 2 C) 4 D) 1

SOL: Average electric energy density = Average magnetic energy density

47. The resistivity (ρ) of semiconductor varies with temperature. Which of the following curve represents the correct behaviour?

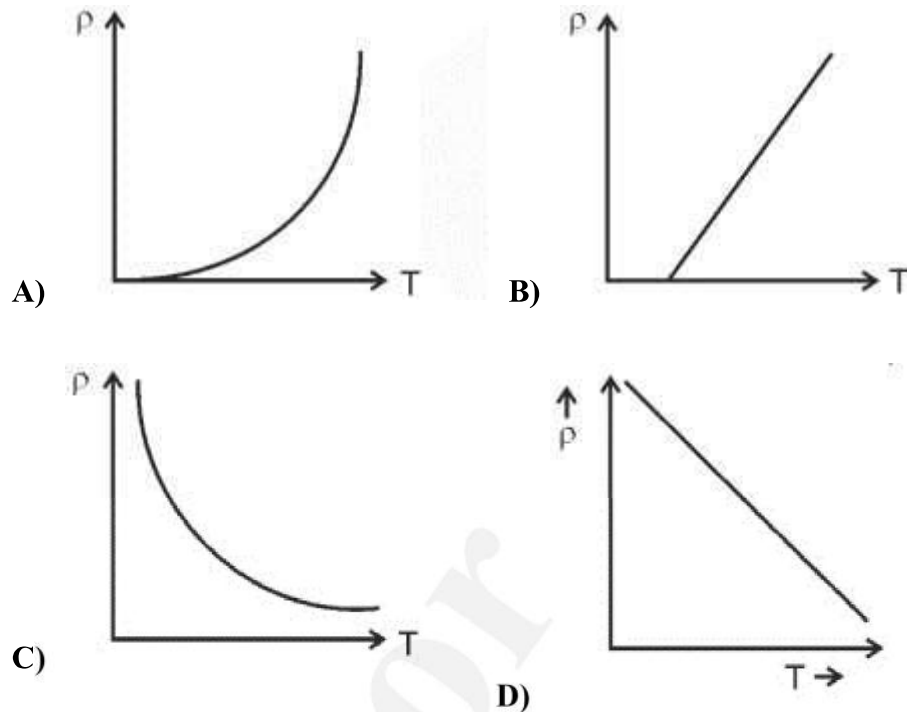

SOL: In semiconductors when small amount of energy is supplied then electrons easily move to conduction band becoming free to move within lattice.

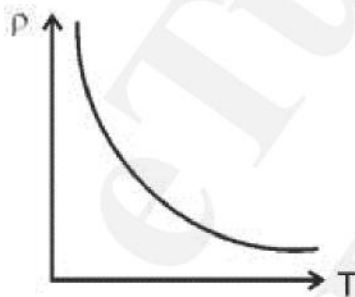

48. A long straight wire of circular cross-section (radius a) is carrying steady current I . The current I is uniformly distributed across this cross-section. The magnetic field is
- A) inversely proportional to r in the region $r < a$ and uniform throughout in the region $r > a$
 - B) directly proportional to r in the region $r < a$ and inversely proportional to r in the region $r > a$
 - C) zero in the region $r < a$ and inversely proportional to r in the region $r > a$
 - D) uniform in the region $r < a$ and inversely proportional to distance r from the axis, in the region $r > a$

SOL:

Loading [MathJax]/jax/element/mml/optable/BasicLatin.js is labelled as **Assertion A** and the other is labelled as **Reason R**.

Assertion A: Earth has atmosphere whereas moon doesn't have any atmosphere.

Reason R: The escape velocity on moon is very small as compared to that on earth.

In the light of the above statements, choose the correct answer from the options given below:

- A) Both A and R are correct but R is NOT the correct explanation of A B) A is false but R is true
C) Both A and R are correct and R is the correct explanation of A D) A is true but R is false

SOL: Because of lower escape velocity on surface of moon the average velocity of gas molecules remains higher than the escape velocity making moon unable to hold atmosphere.

50. The kinetic energy of an electron, α -particle and a proton are given as $4K$, $2K$ and K respectively. The de-Broglie wavelength associated with electron α -particle and the proton are as follows:

- A) B) C) D)

SOL:

51. The radius of fifth orbit of Li^{++} is _____ $\times 10^{-12}$ m. Take: radius of hydrogen atom = 0.51 \AA

SOL: = 425×10^{-12} m

52. A parallel plate capacitor with plate area A and plate separation d is filled with a dielectric material of dielectric constant $K = 4$. The thickness of the dielectric material is x , where $x < d$.



Let C_1 be the capacitance of the system for $x = 0$ and C_2 for $x = d$, respectively. If the value of C_1/C_2 is _____ .

SOL: = $3 \mu\text{F}$

53. A particle of mass 10 g moves in a straight line with retardation $2x$, where x is the displacement in SI units. Its loss of kinetic energy for above displacement is $n \text{ J}$. The value of n will be _____ .

SOL: $v dv = -a dx$

54. Two identical circular wires of radius 20 cm and carrying current are placed in perpendicular planes as shown in figure. The net magnetic field at the centre of the circular wires is _____ $\times 10^{-8} \text{ T}$.

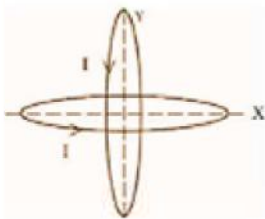

(Take $\pi = 3.14$)

SOL: = $2\pi \times 10^{-8} \text{ T}$

55. A person driving car at a constant speed of 15 m/s is approaching a vertical wall. The person notices a change of 40 Hz in the frequency of his car's horn upon reflection from the wall. The frequency of horn is _____ Hz.

(Given: Speed of sound : 30 m/s)

SOL:

56. A pole is vertically submerged in swimming pool, such that it gives a length of shadow 2.15 m within water when sunlight is incident at an angle of 30° with the surface of water. If swimming pool is filled to a height of 1.5 m , then the height of the pole above the water surface in centimeters is ($n_w = 4/3$)

SOL:

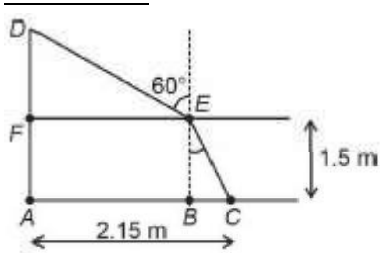

$$AB = 2.15 - BC = 0.8686\text{ m}$$

$$DF = AB \tan 30^\circ = 0.5015\text{ m} \approx 50\text{ cm}$$

57. A steel rod has a radius of 20 mm and a length of 2.0 m . A force of 62.8 kN stretches it along its length. Young's modulus of steel is $2.0 \times 10^{11}\text{ N/m}^2$. The longitudinal strain produced in the wire is _____ $\times 10^{-5}$

SOL: Strain

58. An ideal transformer with purely resistive load operates at 12 kV on the primary side. It supplies electrical energy to a number of nearby houses at 120 V . The average rate of energy consumption in the houses served by the transformer is 60 kW . The value of resistive load (R_s) required in the secondary circuit will be _____ $\text{m}\Omega$.

SOL:

59. The length of a metallic wire is increased by 20% and its area of cross section is reduced by 4% . The percentage change in resistance of the metallic wire is _____.

SOL: and

$$R' = 1.25 R$$

60. Two identical solid spheres each of mass 2 kg and radii 10 cm are fixed at the ends of a light rod. The separation between the centres of the spheres is 40 cm . The moment of inertia of the system about an axis perpendicular to the rod passing through its middle point is _____ $\times 10^{-3}\text{ kg}\cdot\text{m}^2$.

SOL: $= 0.16 + 0.016$

$$I = 0.176$$

$$176 \times 10^{-3}\text{ kg}\cdot\text{m}^2$$

Chemistry

61. Which of the following options are correct for the reaction?

A. Redox reaction

Loading [MathJax]/jax/element/mml/optable/BasicLatin.js

- B. Displacement reaction
 C. Decomposition reaction
 D. Combination reaction

Choose the correct answer from the options given below:

- A)** A only **B)** A and D only **C)** A and B only **D)** C and D only

SOL: (A) Oxidation state of zinc is changing from 0 to +2 .

(B) Zinc is displacing Au from complex.

62. The setting time of Cement is increased by adding

- A)** Clay **B)** Silica **C)** Gypsum **D)** Limestone

SOL: Gypsum is added to slow down the process of setting of the cement so that it gets sufficiently hardened.

63. A compound is formed by two elements X and Y. The element Y forms cubic close packed arrangement and those of element X occupy one third of the tetrahedral voids. What is the formula of the compound?

- A)** X_2Y_3 **B)** X_3Y_2 **C)** X_3Y **D)** XY_3

SOL:

64. The standard electrode potential of M^+/M in aqueous solution does not depend on

- A)** Hydration of a gaseous metal ion **B)** Sublimation of a solid metal
C) Ionisation of a solid metal atom **D)** Ionisation of a gaseous metal atom

SOL: Ionisation energy is defined for gaseous atom and not solid atom.

65. Match List I and List II

LIST I Vitamin	LIST II Deficiency disease
A. Vitamin A	I. Beri-Beri
B. Thiamine	II. Cheilosis
C. Ascorbic acid	III. Xerophthalmia
D. Riboflavin	IV. Scurvy

Choose the correct answer from the options given below

- A)** A-III, B-I, C-IV, D-II **B)** A-IV, B-I, C-III, D-II **C)** A-IV, B-II, C-III, D-I

D) A-III, B-II, C-IV, D-I

SOL: Vitamin A : Xerophthalmia

Thiamine : Beri Beri

Ascorbic acid : Scurvy

Riboflavin : Cheilosis

66. The difference between electron gain enthalpies will be maximum between :

A) Ne and F **B)** Ar and F **C)** Ne and Cl **D)** Ar and Cl

SOL: ΔH_{eg} for chlorine = $-349 \text{ kJ mole}^{-1}$

ΔH_{eg} for Neon = $+116 \text{ kJ mole}^{-1}$

67. The possibility of photochemical smog formation is more at

A) Marshy lands **B)** Industrial areas **C)** Himalayan villages in winter

D) The places with healthy vegetation

SOL: Photochemical smog formation will be more at Industrial areas.

68. Match List I with List II

LIST I Oxide		LIST II Type of bond	
A.	N_2O_4	I.	1 N = O bond
B.	NO_2	II.	1 N – O – N bond
C.	N_2O_5	III.	1 N – N bond
D.	N_2O	IV.	1 N = N/N \equiv N bond

Choose the correct answer from the options given below:

A) A-III, B-I, C-II, D-IV **B)** A-II, B-IV, C-III, D-I **C)** A-III, B-I, C-IV, D-II

D) A-II, B-I, C-III, D-IV

SOL:

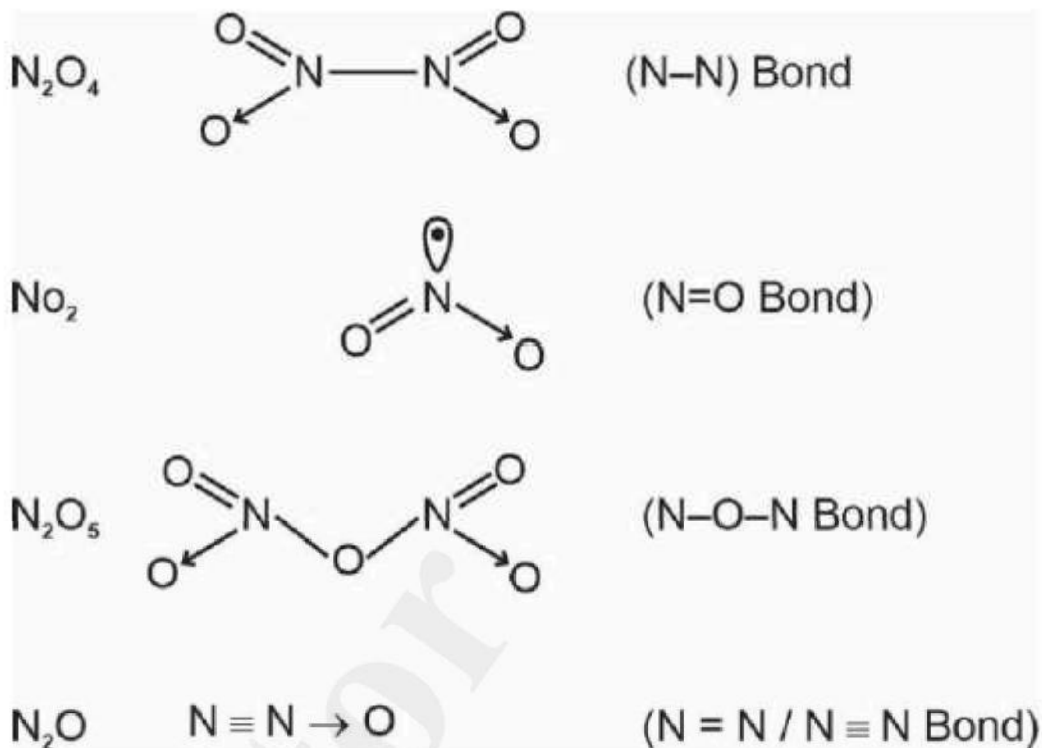

69. Strong reducing and oxidizing agents among the following, respectively, are

- A) Ce^{3+} and Ce^{4+} B) Ce^{4+} and Tb^{4+} C) Ce^{4+} and Eu^{2+} D) Eu^{2+} and Ce^{4+}

SOL: Lanthanoids have +3 oxidation state as stable oxidation state

+4 oxidation state : Oxidising agents

+2 oxidation state : Reducing agents

70. The major product formed in the following reaction is

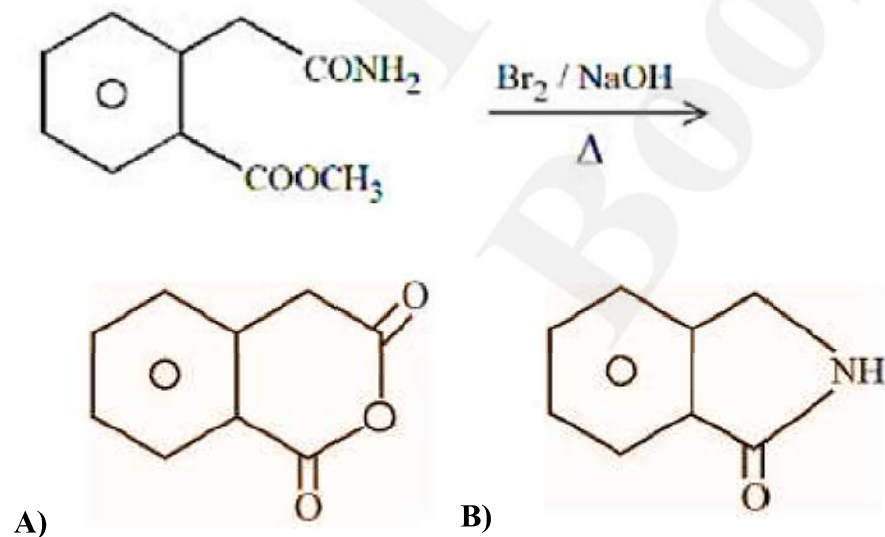

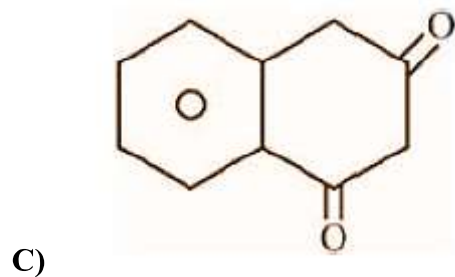

SOL:

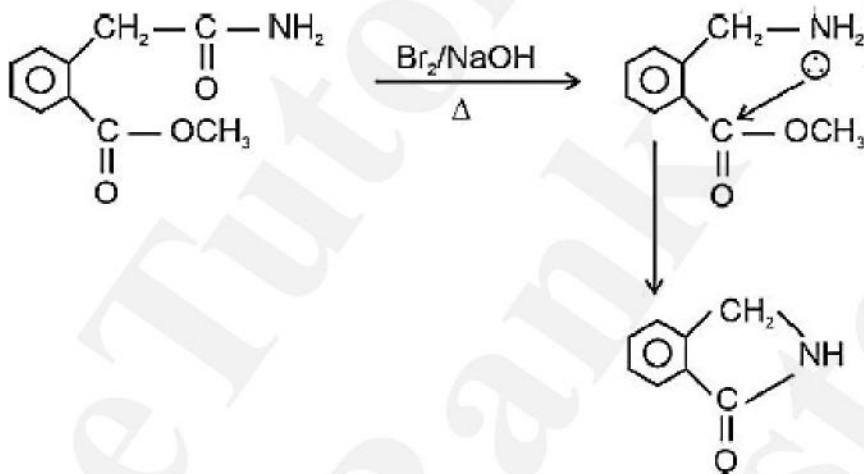

71. For the reaction

The correct statement is

- A) Br⁻ can act as competing nucleophile. B) The reaction can occur in acetic acid also.
 C) The transition state formed in the above reaction is less polar than the localised anion.
 D) The solvent used in the reaction solvates the ions formed in rate determining step

SOL: NaBr is not soluble in acetone and hence reaction shifts in forward reaction and reaction is called Finkelstein reaction which proceeds through S_N2 mechanism

For S_N2 reactions, transition state formed is less polar than the localised anion.

72. Polymer used in orlon is:

Loading [MathJax]/jax/element/mml/optable/BasicLatin.js

A) Polyethene B) Polycarbonate C) Polyamide D) Polyacrylonitrile

SOL: Orlon is polyacrylonitrile

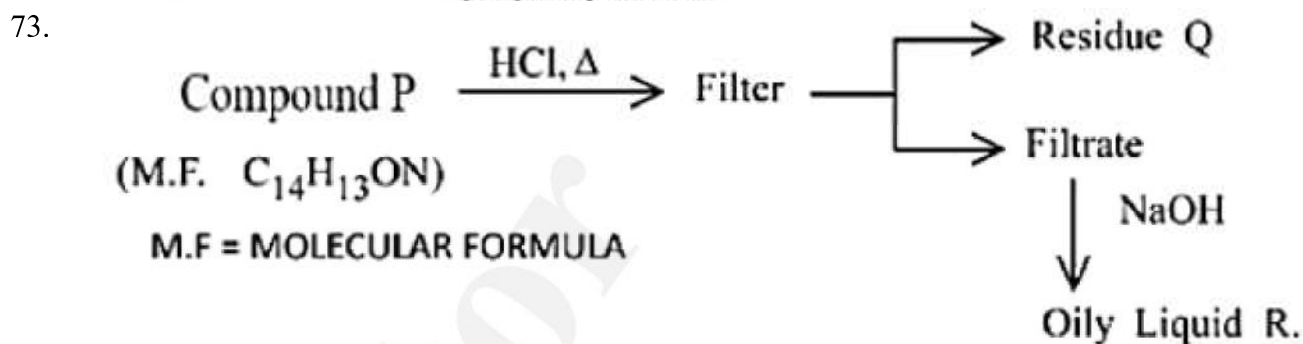
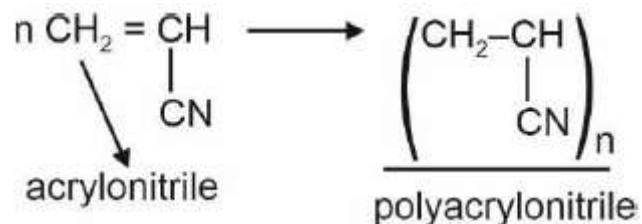

Compound P is neutral, Q gives effervescence with NaHCO_3 while R reacts with Hinsberg's reagent to give solid soluble in NaOH . Compound P is

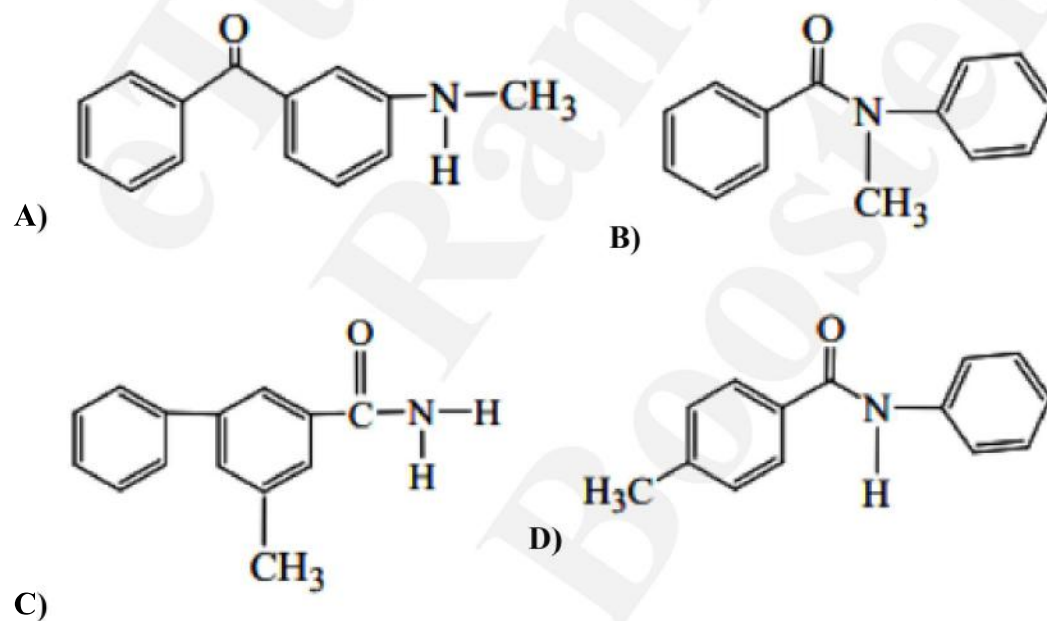

SOL: R is 1° Amine

Q is Carboxylic Acid

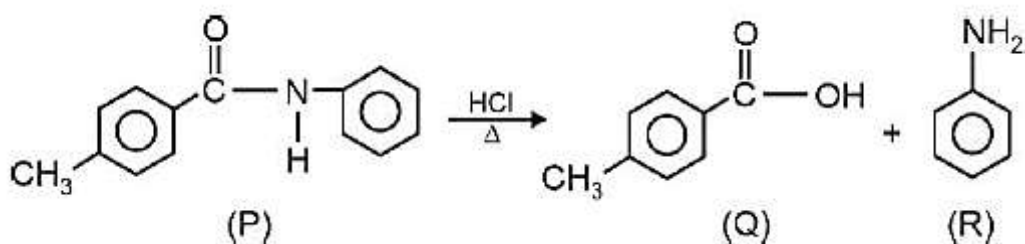

74. Match List I with List II

LIST I		LIST II	
Enzymatic reaction		Enzyme	
A.	Sucrose \rightarrow Glucose and Fructose	I.	Zymase
B.	Glucose \rightarrow ethyl alcohol and CO_2	II.	Pepsin
C.	Starch \rightarrow Maltose	III.	Invertase
D.	Proteins \rightarrow Amino acids	IV.	Diastase

Choose the correct answer from the options given below.

- A) A-I, B-II, C-IV, D-III B) A-III, B-I, C-IV, D-II C) A-III, B-I, C-II, D-IV
 D) A-I, B-IV, C-III, D-II

SOL: (A)

(B)

(C)

(D)

75. For a concentrated solution of a weak electrolyte (K_{eq} = equilibrium constant) A_2B_3 of concentration 'c', the degree of dissociation ' α ' is

- A) B) C) D)

SOL:

76. Match List-I with List-II.

LIST I		LIST II	
Element detected		Reagent used/Product formed	
A.	Nitrogen	I.	$\text{Na}_2[\text{Fe}(\text{CN})_5\text{NO}]$
B.	Sulphur	II.	AgNO_3
C.	Phosphorus	III.	$\text{Fe}_4[\text{Fe}(\text{CN})_6]_3$
D.	Halogen	IV.	$(\text{NH}_4)_2\text{MoO}_4$

Choose the correct answer from the options given below:

Loading [MathJax]/jax/element/mml/optable/BasicLatin.js

- A) $A \rightarrow \text{III}; B \rightarrow \text{I}; C \rightarrow \text{IV}; D \rightarrow \text{II}$ B) $A \rightarrow \text{II}; B \rightarrow \text{IV}; C \rightarrow \text{I}; D \rightarrow \text{III}$
- C) $A \rightarrow \text{IV}; B \rightarrow \text{II}; C \rightarrow \text{I}; D \rightarrow \text{III}$ D) $A \rightarrow \text{II}; B \rightarrow \text{I}; C \rightarrow \text{IV}; D \rightarrow \text{III}$

SOL: Nitrogen : $\text{Fe}_4[\text{Fe}(\text{CN})_6]_3$ (Prussian Blue)

Sulphur : $\text{Na}_2[\text{Fe}(\text{CN})_5\text{NO}]$

Phosphorous : $(\text{NH}_4)_2\text{MoO}_4$

Halogen : AgNO_3

77. Given below are two statements, one is labelled as **Assertion A** and the other is labelled as **Reason R**.

Assertion A: The spin only magnetic moment value for $[\text{Fe}(\text{CN})_6]^{3-}$ is 1.74 BM, whereas for $[\text{Fe}(\text{H}_2\text{O})_6]^{3+}$ is 5.92 BM.

Reason B: In both complexes, Fe is present in +3 oxidation state.

In the light of the above statements, choose the correct answer from the options given below.

- A) A is false but R is true B) A is true but R is false
- C) Both A and R are true but R is NOT the correct explanation of A
- D) Both A and R are true and R is the correct explanation of A

SOL: $\rightarrow \text{CN}^-$ is strong field ligand and hence pairing will take place.

$\rightarrow \text{H}_2\text{O}$ is a weak field ligand and hence pairing will not take place.

78. Match List-I with List-II.

LIST-I Name of reaction		LIST-II Reagent used	
A.	Hell-Volhard-Zelinsky reaction	I.	$\text{NaOH} + \text{I}_2$
B.	Iodoform reaction	II.	(i) $\text{CrO}_2\text{Cl}_2, \text{CS}_2$ (ii) H_2O
C.	Etard reaction	III.	(i) $\text{Br}_2/\text{red phosphorus}$ (ii) H_2O
D.	Gatterman-Koch reaction	IV.	$\text{CO}, \text{HCl}, \text{anhyd. AlCl}_3$

Choose the correct answer from the options given below:

Loading [MathJax]/jax/element/mml/optable/BasicLatin.js

A) A → III; B → I; C → II; D → IV B) A → I; B → II; C → III; D → IV

C) A → III; B → II; C → I; D → IV D) A → III; B → I; C → IV; D → II

SOL: (A) Hell-Volhard-Zelinsky reaction:

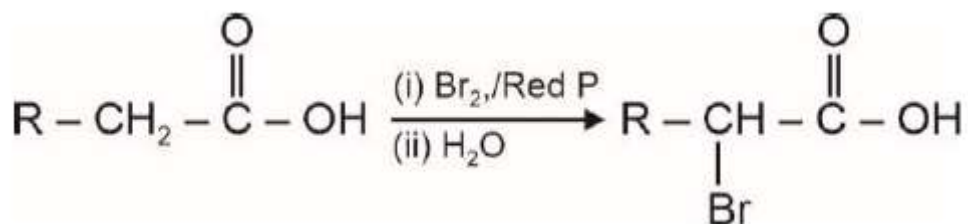

(B) Iodoform reaction:

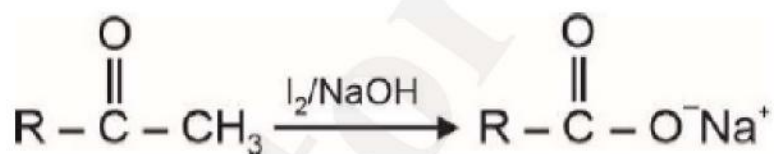

(C) Etard reaction:

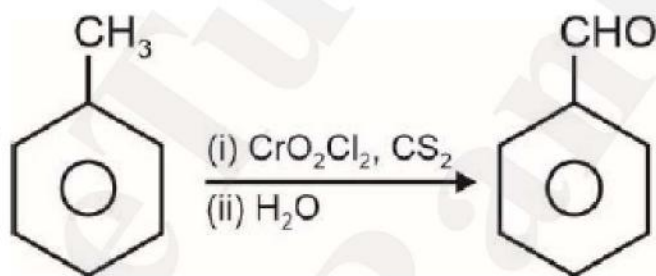

(D) Gatterman-Koch reaction

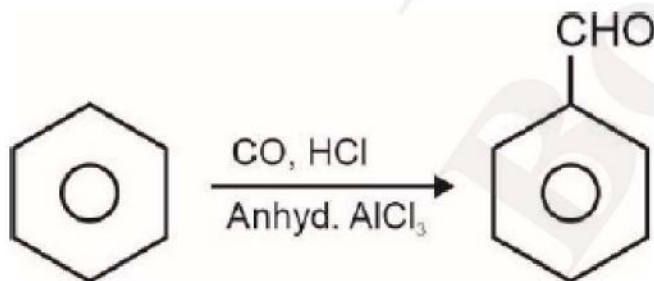

79. Given below are two statements, one is labelled as **Assertion A** and the other is labelled as **Reason R**.

Assertion A: Loss of electron from hydrogen atom results in nucleus of $\sim 1.5 \times 10^{-3}$ pm size.

Reason R: Proton (H^+) always exists in combined form.

In the light of the above statements, choose the most appropriate answer from the options given below:

- A) Both A and R are correct and R is the correct explanation of A
 B) A is correct but R is not correct C) A is not correct but R is correct
 D) Both A and R are correct but R is NOT the correct explanation of A

SOL: Size of nucleus is of order

$$1.5 \times 10^{-15} \text{ m or } 1.5 \times 10^{-3} \text{ pm}$$

H^+ always exists in combined form.

There is no relation between two statements and hence option (4) is the answer.

80. The major products A and B from the following reactions are:

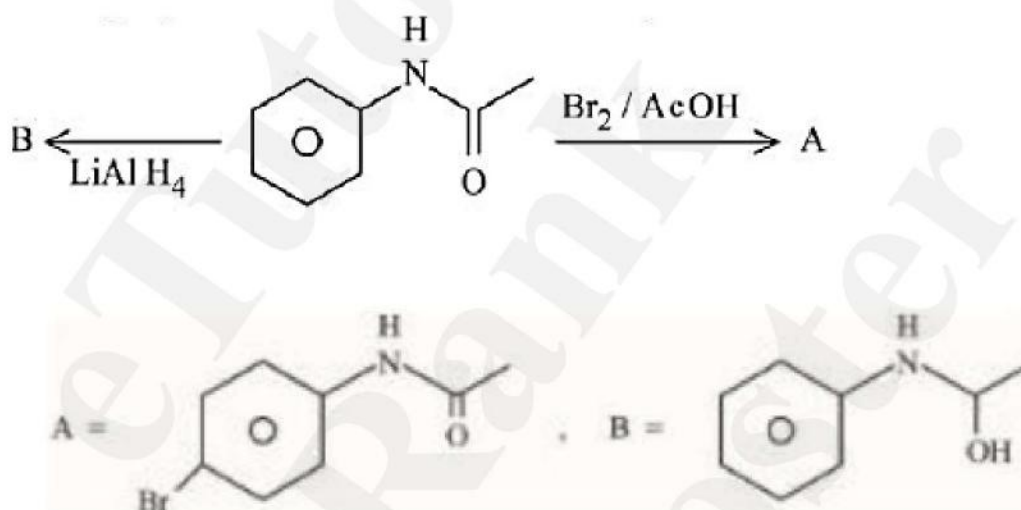

A)

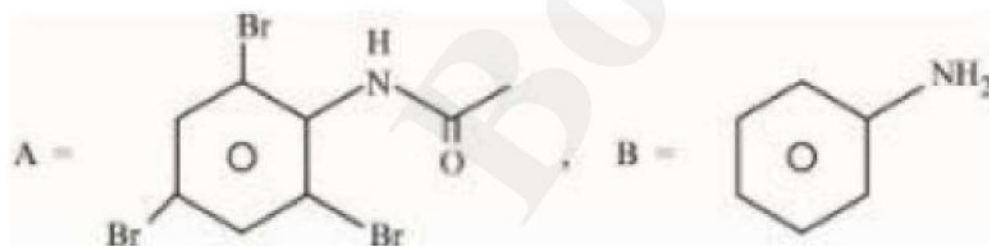

B)

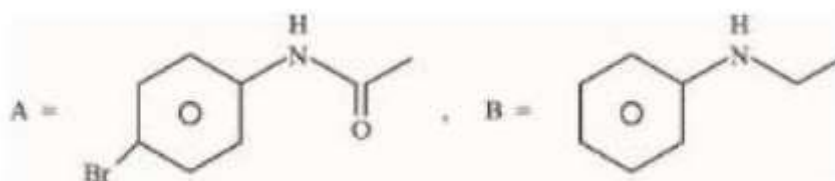

C)

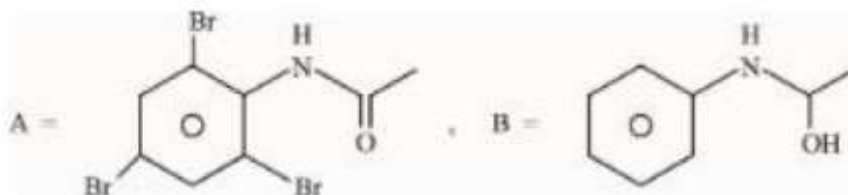

D)

SOL:

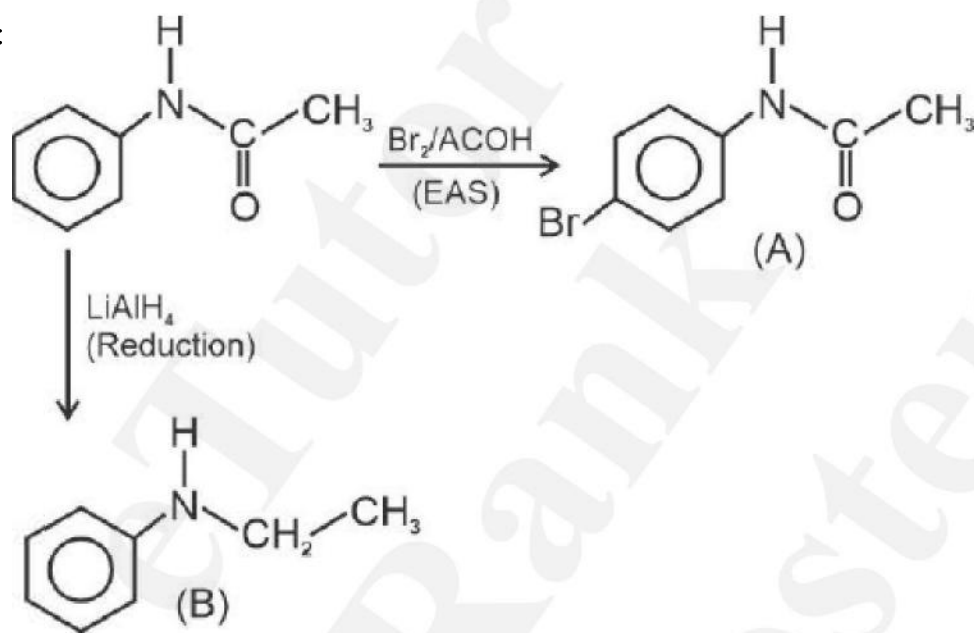

81. Mass of Urea ($\text{NH}_2\text{CONHN}_2$) required to be dissolved in 1000 g of water in order to reduce the vapour pressure of water by 25 % is g. (Nearest integer)

Given : Molar mass of N, C, O and H are 14, 12, 16 and 1 g mol^{-1} respectively.

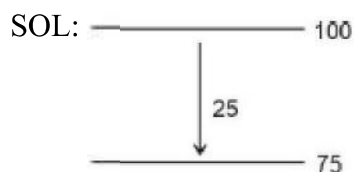

$$= 1111.11 \text{ gm}$$

82. The value of $\log K$ for the reaction at 298 K is _____. (Nearest integer)

Given : $\Delta H^\circ = -54.07 \text{ kJ mol}^{-1}$

$\Delta S^\circ = 10 \text{ JK}^{-1} \text{ mol}^{-1}$

(Take $2.303 \times 8.314 \times 298 = 5705$)

$$= -57.05 \text{ kJ / mole}$$

$$\Delta G^\circ = -2.303 R T \log K_{\text{eq}}$$

$$-57.05 \times 1000 = -2.303 \times 8.314 \times 298 \log K_{\text{eq}}$$

$$-57.05 \times 1000 = -5705 \log K_{\text{eq}}$$

$$10 = \log K_{\text{eq}}$$

83. In ammonium - phosphomolybdate, the oxidation state of Mo is +

SOL: Ammonium phosphomolybdate is

(+6)

84. Number of bromo derivatives obtained on treating ethane with excess of Br_2 in diffused sunlight is

SOL: 6 Bromine atoms : 1 product possible

5 Bromine atoms : 1 product possible

4 Bromine atoms : 2 products possible

3 Bromine atoms : 2 products possible

2 Bromine atoms : 2 products possible

1 Bromine atom : 1 product possible

Total 9 products possible

85. For the adsorption of hydrogen on platinum, the activation energy is 30 kJ mol^{-1} and for the adsorption of hydrogen on nickel, the activation energy is 41.4 kJ mol^{-1} . The logarithm of the ratio of the rates of chemisorption on equal areas of the metals at 300 K is _____ (Nearest integer)

Given : $\ln 10 = 2.3$

$$R = 8.3 \text{ J K}^{-1} \text{ mol}^{-1}$$

SOL: $= 1.990 \approx 2$

86. The number of species from the following which have square pyramidal structure is _____

SOL: and have square pyramidal structure.

87. If 5 moles of BaCl_2 is mixed with 2 moles of $\text{Na}_3 \text{PO}_4$, the maximum number of moles of $\text{Ba}_3(\text{PO}_4)_2$ formed is _____ (Nearest integer)

SOL:

5	2	(-)
↓	↓	↓
3	0	1 mole
↓	↓	↓
2	0	1 mole

mole of $\text{Ba}_3(\text{PO}_4)_2$ formed = 1

88. Number of ambidentate ligands in a representative metal complex $[\text{M}(\text{en})(\text{SCN})_4]$ is _____

en = ethylenediamine

Loading [MathJax]/jax/element/mml/optable/BasicLatin.js

SOL: 4 SCN ligands are ambidentate.

89. The wavelength of an electron of kinetic energy 4.50×10^{-29} J is _____ $\times 10^{-5}$ m. (Nearest integer)
 Given: mass of electron is 9×10^{-31} kg, $h = 6.6 \times 10^{-34}$ Js

SOL:

90. Consider the graph of Gibbs free energy G vs extent of reaction. The number of statement/s from the following which are true with respect to points (a), (b) and (c) is

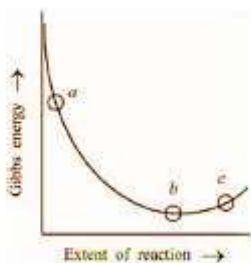

- A. Reaction is spontaneous at (a) and (b)
 B. Reaction is at equilibrium at point (b) and nonspontaneous at point (c)
 C. Reaction is spontaneous at (a) and nonspontaneous at (c)
 D. Reaction is non-spontaneous at (a) and (b)

SOL: At point a : Slope = -ve

$$dG = -ve$$

⇒ spontaneous

At point b: Slope = 0

$$dG = 0$$

⇒ equilibrium

At point c: Slope = +ve

$$dG = +ve$$

⇒ non-spontaneous

Print